



ASSEMBLY AND CARE INSTRUCTIONS

POLARIS QUAD BAR 4000

VERSION: 8920125 (Revised 03/18)



SALES AND SERVICE spiethamerica.com

Canada and International
135 Forestview Road, Oro-Medonte
Ontario, Canada L3V 0R4

Toll-Free: (800) 563-6479
Telephone: (705) 325-2274
Fax: (705) 325-1485

sevice.ca@spiethamerica.com

USA
3327 Ranger Road
Lansing, MI 48906

Toll-Free: (800) 331-8068
Telephone: (517) 999-8230
Fax: (517) 999-8245

service.usa@spiethamerica.com

The **Polaris Quad Bar System** is a multi-functional set of bars which can be used for all program levels from preschool to team. There are 100's of set ups which can accommodate different skill development, training, conditioning and obstacle courses.

Rails are sold separately (Clevis-6) and (Clevis-8).

- Highest rail setting 167.6 cm (5' 6") adjusts in 1" increments.
- Lowest rail setting 20.3 cm (8")

The **Polaris Quad Bar System** is manufactured of the finest materials and has been thoroughly inspected before leaving our plant. We are sure you will be pleased with its quality, durability and performance.



The exclamation mark symbol when seen in this manual is used to indicate warnings or items that require special attention during the use or assembly of the apparatus.



Assembly, set-up and adjustment of this equipment should only be undertaken by qualified persons. At no time should children or other unqualified persons undertake the assembly, set-up, installation or adjustment of this equipment.

For assembly, set-up and adjustment instructions, please read and follow all instructions of this manual as they apply to your particular piece or pieces of equipment.

Be sure to read and follow all Safety Instructions in the last Section of this manual before attempting to use the apparatus!

Tools Required:

- Tape measure
- Hammer
- 5/8" diameter carbide concrete drill bit
- Anchor setting tool or Drift punch with a 5/16" diameter & at least 1.5" long end
- Hammer drill
- 3/4" or 19mm Socket and Ratchet
- 2 adjustable wrenches
- 6ft to 8ft Step Ladder
- Two levels

Polaris Quad Bar Package:

The 4000 Polaris Quad Bar Consists of:

- (4) Polaris Bar Uprights
- (2) Center plates
- (8) Polaris Bar Rail Carriers
- (8) Polaris Bar Adjusting Tubes
- Anchors & Hardware

1. Assembly & Installation

1.1. Preparation to Assembly



Prepare a clean area to assemble the apparatus.



The assembly and set-up of the apparatus requires a minimum of two qualified persons. Do not attempt the assembly and set-up of this apparatus alone!

1. Pre-assemble (8) Rail Carriers on (8) Adjusting Tubes (see Fig. 1).



Always make sure to engage the Spin Snap Lock Handles so that the pin drops into a hole and that it is properly tightened by turning the knob clockwise (see Fig. 3b).

2. Position the **Center Plate** on the floor and mount (4) **Adjusting Tubes** on the **Center Plate** with the **Spin Snap Locks facing outward** (see Fig. 1a & 2). Assemble using the supplied hardware as shown below (see Fig. 2).

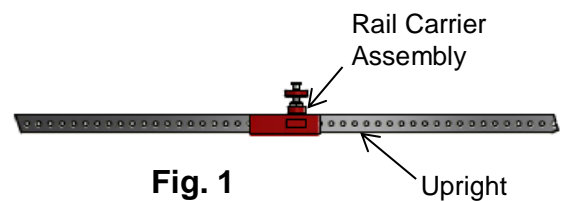

Fig. 1

3. Now assemble the **Top Center Plate** (see Fig. 2 & 3a).

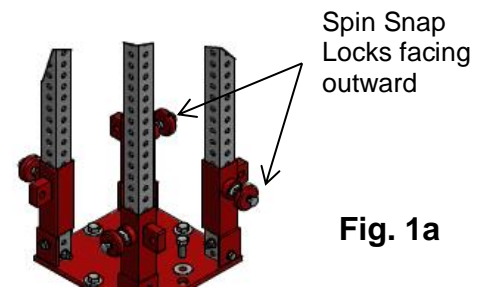

Fig. 1a

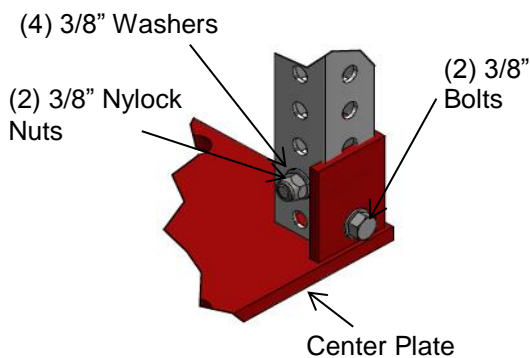

Fig. 2

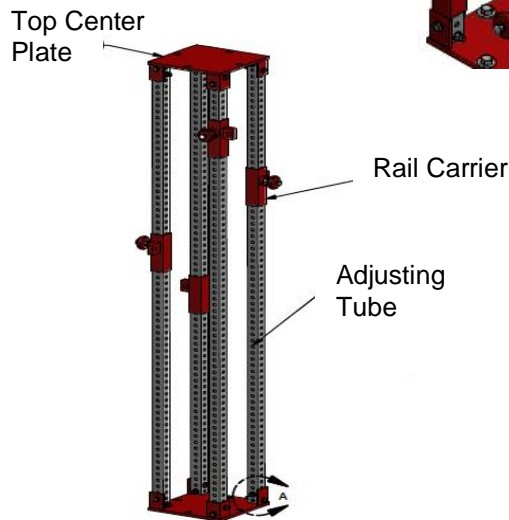

Fig. 3a

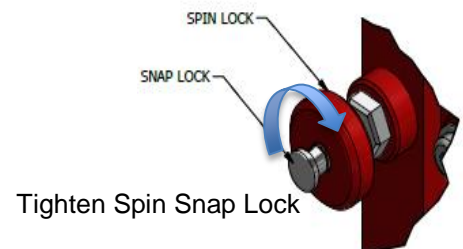

Fig. 3b

1.2. Installing Concrete Anchors



To determine anchor locations, please refer to the following section for your specific equipment to be anchored.

Tools Required (customer supplied):

- Tape measure
- Anchor setting tool or punch with a $\frac{5}{16}$ " diameter & 1.5" long end
- $\frac{5}{8}$ " diameter carbide tipped concrete drill bit
- Hammer drill
- $\frac{3}{4}$ " or 19mm Socket, Extension and Ratchet
- Hammer
- Safety glasses



Never place a floor anchor into a seam/crack, or an area within 9" from a seam/crack or outside edge of the concrete floor.

1. With the $\frac{5}{8}$ " carbide drill bit installed in the Hammer drill, drill a hole into the concrete to 2 inches ($+\frac{1}{8}$ ").
2. Use a shop vacuum or turkey baster to remove all dust and concrete chips out of the holes. Ensure the hole depth is at least 2 inches ($+\frac{1}{8}$ ").
3. Turn a hex head bolt 3 full turns into a floor anchor, and insert it into the drilled hole.
4. Use the hammer to tap the top of the bolt until the floor anchor is flush with or just below the top of the concrete.
5. Remove the hex head bolt, proceed to set the anchor and lock it in place!

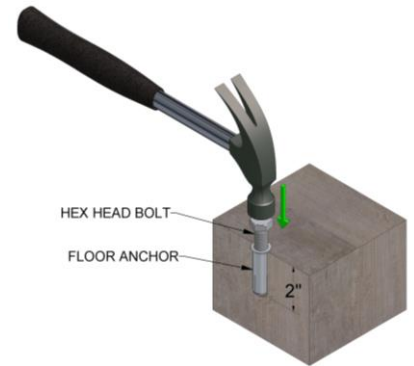

The step of locking or setting the anchors is critical. Ensure that it is done correctly!

6. Using a punch or setting tool (customer supplied), set the floor anchor by striking the plunger in the center of the floor anchor. Strike the setting tool or punch with a hammer repeatedly, to expand the anchor in the hole.

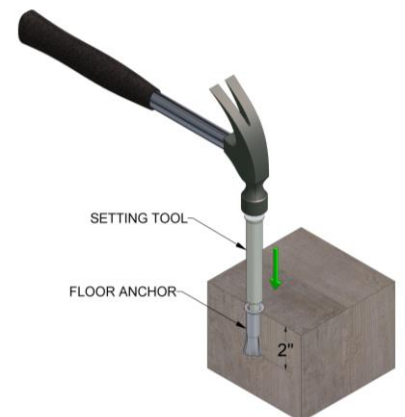

When attaching equipment to floor anchors, a bolt torque value of 20 ft lbs is recommended.

1.3 Installation

1.3.1 Anchoring the Center Frame



Floor anchors must be at least nine inches away from any cracks or holes in the concrete. Before starting installation, use the layout diagram to check for cracks (see below). This will ensure that all the anchors can be properly installed.



Read 1.2. “Installing Concrete Anchors” on previous page carefully, for properly installing those floor anchors. Installing the concrete anchors is critical for this apparatus to function safely!

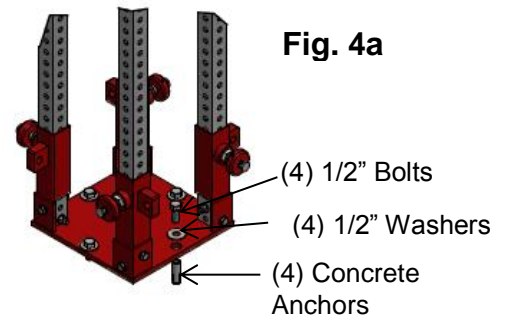
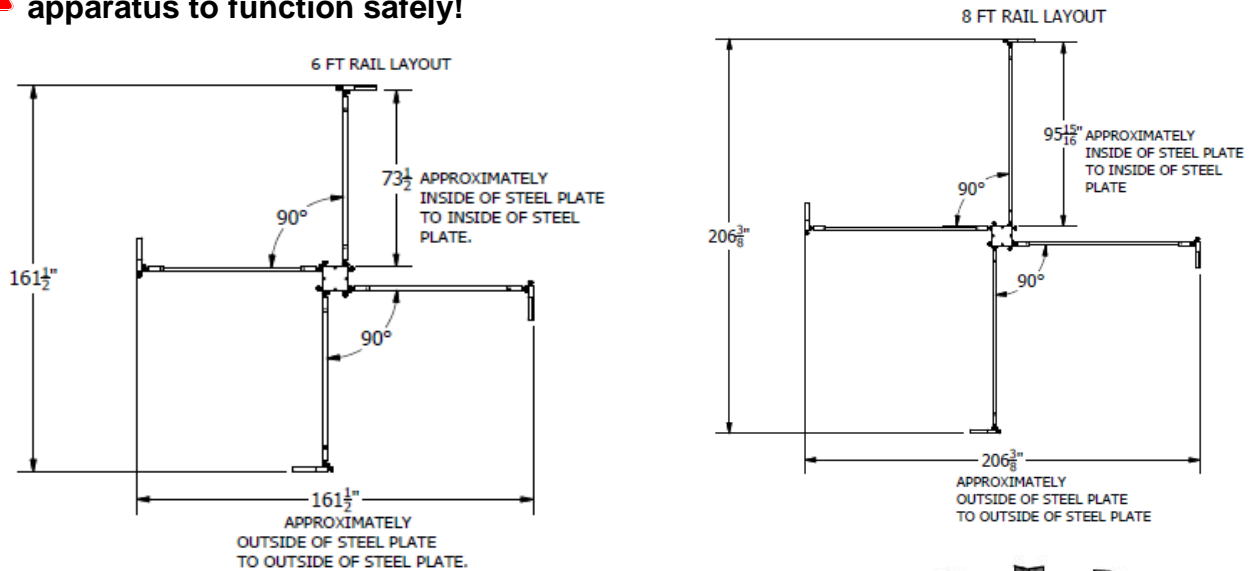

1. Layout and mark the apparatus footprint referring to the measurements on one of the diagrams above.
2. Locate and mark the location of the **Center Plate** anchors, using the **Center Plate** as a guide.
3. Drill and install the **(4)** concrete anchors using the **Center Plate** as a guide (see **Fig. 4a**).
4. Fasten the **Center Frame** down using the supplied bolts and washers (see **Fig. 4a**).
5. Check installed **Center Frame** to make sure it is sitting flat on the concrete floor. Once the bolts are properly tightened, make sure the **Center Frame** is level (see **Fig. 4b**). Shim the center plate if required.

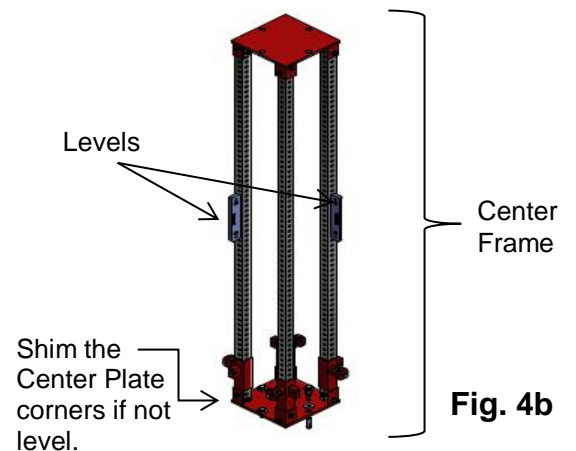

1.3.2 Assembling and Installing the Uprights

1. Assemble the (4) remaining **Adjusting Tubes** into the **Uprights** as shown below (see Fig. 4).

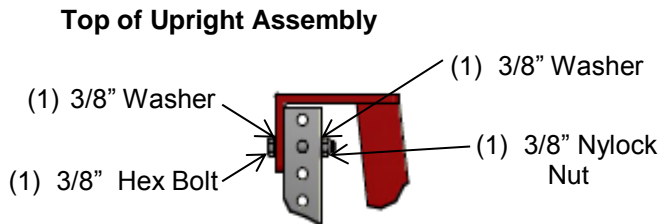
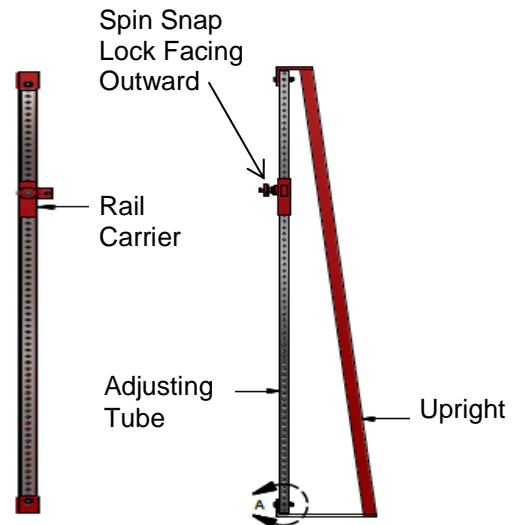

Fig. 4



1.3.3 Layout

1. Now place (1) **Rail** into both **Rail Carriers** across from one another to determine the proper location of the **Upright** (see Fig. 5 & 7).



Install the Rail ensuring the mounting hardware bolts are securely tightened on the Rail Carriers.

2. Set the **Rail Carrier** to the lowest position on the **Adjusting Tubes**. Make sure the **Spin Snap Lock** engages into the hole on the **Adjusting Tubes** in the same hole positions, but do not tighten the **Snap Lock** at this point (see Fig. 7).

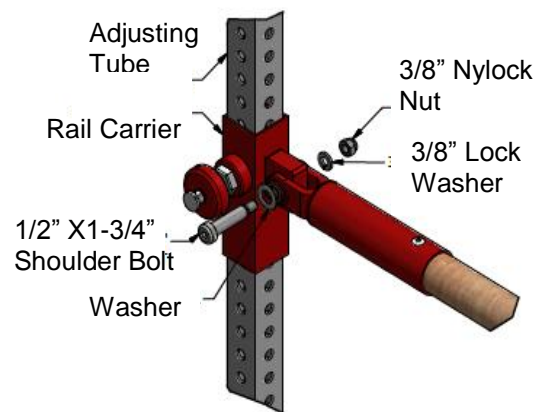

Fig. 5



Make sure that both Rail Carriers are adjusted to the same height. This step is critical so the apparatus will function properly.

3. **Align each Upright with the center frame as layouts below (6' or 8').** Measure all dimensions as shown below before proceeding to the next step (see **Fig. 6a & 6b**).

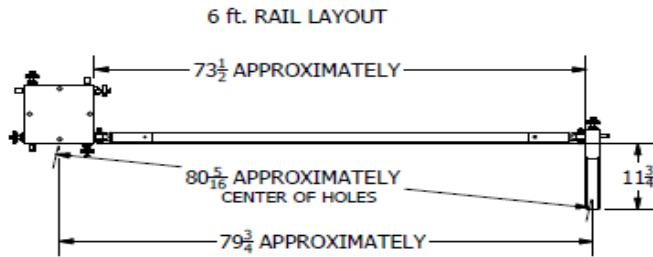

Fig. 6a

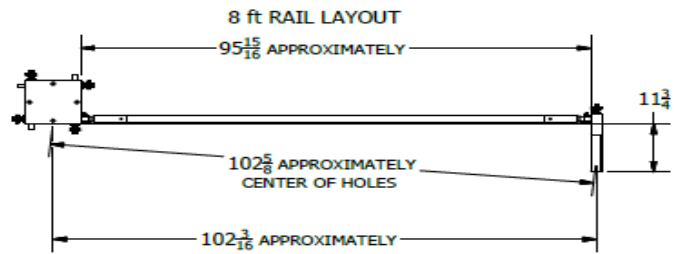

Fig. 6b

4. Check function of the **Uprights** by moving the **Rail Carrier** up and down. Adjust the **Uprights** location until the **Rail** adjusts up and down easily.

1.3.4 Anchoring the Upright Assembly

1. Make sure the **Upright Base Plate** is sitting flat on the concrete. Locate and mark the location of the **Upright Base Assembly** concrete anchors, using the **Upright Base Assembly** as a guide (see **Fig. 7**).



Keep in mind that the assembly is not stable at this point and that each side must be supported at all times during the installation.

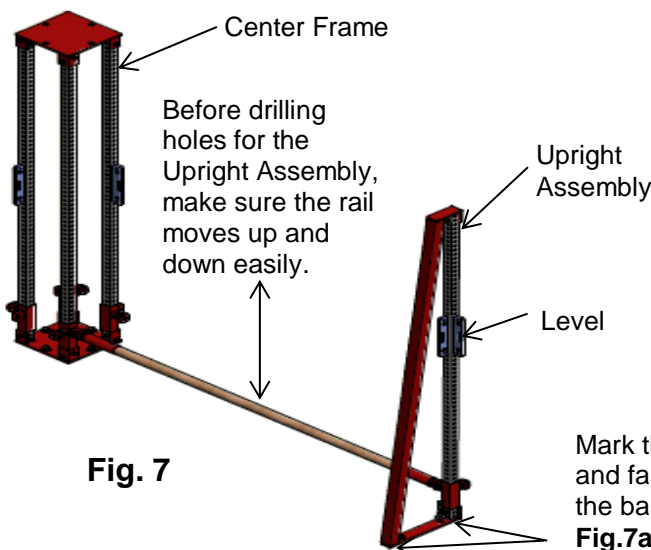

Fig. 7

Mark the holes, drill and fasten down the base (see **Fig.7a**).

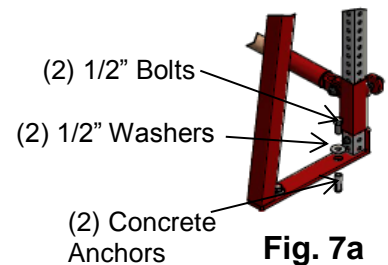

Fig. 7a

2. Drill and install **(2)** concrete anchors using the **Upright Assembly** as a guide (see **Fig. 7 & 7a**).
3. Fasten down the **Upright Assembly** using the supplied bolts and washers (see **Fig. 7a**).
4. Check installed **Upright Assembly** to make sure it is sitting flat on the concrete floor. Once the bolts are properly tightened, make sure the **Upright Assembly** is level (see **Fig. 7**).
5. **Repeat steps 1-4 as above** for anchoring the other **3 remaining Upright Assemblies** (see **Fig 8**).

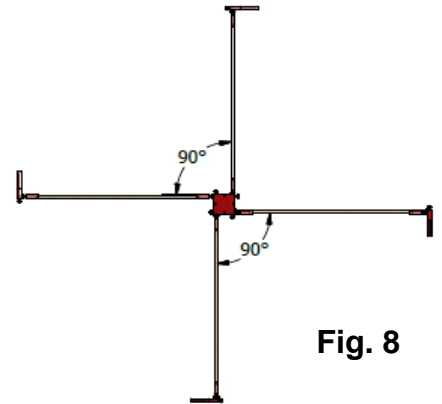

Fig. 8

6. Set the **Rails** to desired height and **Tighten all Spin Lock Knobs securely by turning clockwise before using the apparatus!**

1.4 Height Adjustment

1. Loosen the **Spin Lock Knob** on the **Rail Carrier**.
2. Pull the **Snap Lock** out of the hole in the **Adjusting Tube**.
3. Move the **Rail** up or down to the desired position.
4. Make sure the **Snap Lock** is fully engaged in a hole at the same height on both **Adjusting Tubes**.
5. Tighten the **Spin Lock Knob** on the **Rail Carriers** by turning clockwise direction.



The Rail Carrier Spin Snap Lock must be always tightened after any adjustment is completed and before using the Apparatus!



It is very important to ensure the mounting hardware bolts are always securely tightened on the Adjusting Tubes and anchors properly or personal injury may occur!

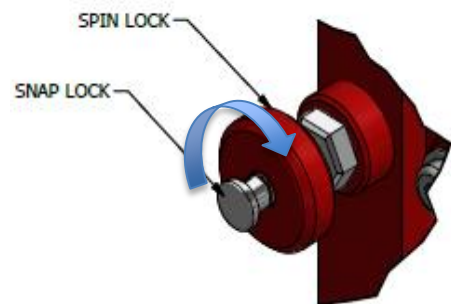

2. Parts List

PARTS LIST			
ITEM	QTY	PART NUMBER	DESCRIPTION
1	8	4000-100-10	ADJUSTING TUBE
2	2	4000-110	CENTER PLATE
3	8	4000-120	RAIL CARRIER
4	4	4000-100	UPRIGHT
5	8	555-254	SPIN SNAP LOCK
6	48	8320009	3/8" Plain Washer
7	24	8305148	3/8" N.C. NYLOCK NUT
8	24	8304070	3/8" N.C. X 2-1/2" L.O. Hex Bolt
9	12	8320011	1/2" Plain Washer
10	12	8306024	1/2" - 13 N.C. EXP. ANCHOR
11	12	8304121	1/2" N.C. - 1-1/4" L.O. Hex Bolt

3. SAFETY



Any activity involving motion or height creates the possibility of serious injury including permanent paralysis and even death, from landing or falling on the neck, head, or other parts of the body.

You assume a risk of serious injury in using this equipment. However, this risk can be reduced by strictly following these rules at all times.

1. Use this equipment **only** under the supervision of a trained and qualified instructor.
2. This equipment **must be used only when protected by proper matting as recommended by the Federation of International Gymnasts (F.I.G.)**. If in doubt concerning proper matting, **do not use this equipment**.
3. This equipment **must be used with proper spotting equipment and qualified spotters suitable to the activity or skill**. Always consult an instructor.
4. **Know your own limitations and the limitations of this equipment**. Follow progressive learning techniques and always consult an instructor.
5. **Always inspect this equipment for proper stability before each use**.
6. **Always inspect this equipment for loose fittings and parts. Replace any worn, defective or missing parts**.
7. **Always inspect this equipment for improper or unsafe installation. If in doubt, do not use this equipment**.